

SEE ISMV1003 FOR SERVICE INSTRUCTIONS.  
LUBRICATE ALL SEALS WITH CLEAN HYDRAULIC OIL PRIOR TO ASSEMBLY.  
DO NOT USE SILICONE BASED LUBRICANTS.

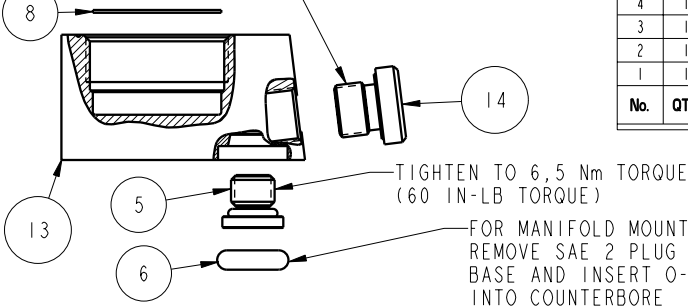

No.	QTY	PART No.	DESCRIPTION	Standard Seal Kit	FKW Seal Kit	Spring Kit
N/A	N/A	ISMV1003	INSTRUCTION SHEET			
N/A	N/A	61100307	SPRING KIT			
N/A	N/A	6V100110	SEAL KIT, FKM			
N/A	N/A	64100110	SEAL KIT, STANDARD			
16	1	39V50039	WIPER, PRESS-IN, (5/8)	X	X	
15	1	81010610	PISTON, WS, FA, 1000 & 4.4 KN			
14	1	43068004	PLUG, SOCH, G1/8			
13	1	41040603	ASSY, BASE, WS, FA, 4.4 KN			
12	1	41040602	BOLT, CONTACT, WS, FA, 4.4 KN			
11	1	39054009	BU RING, (-106)	X	X	
10	1	39051059	O-RING, (6mm x 1.5)	X	X	
9	1	39050037	O-RING, (-015)	X	39V51016	
8	1	39010054	BU RING, (-116)	X	39054004	X
7	1	39010011	SEAL, BEVEL, 3/16 X 3/32 X 3/8	X	39V10011	
6	1	39000068	O-RING, (-202)	X	39V00068	
5	1	30601123	PLUG, SOCH, SAE 2			
4	1	23350062	SPRING, COMPRESSION			X
3	1	23350060	SPRING, COMPRESSION			X
2	1	21430012	WASHER			
1	1	21410076	BHCS, 6-32 x 3/16 SELFLOCK, SST			
No.	QTY	PART No.	DESCRIPTION	Standard Seal Kit	FKW Seal Kit	Spring Kit

## PARTS LIST

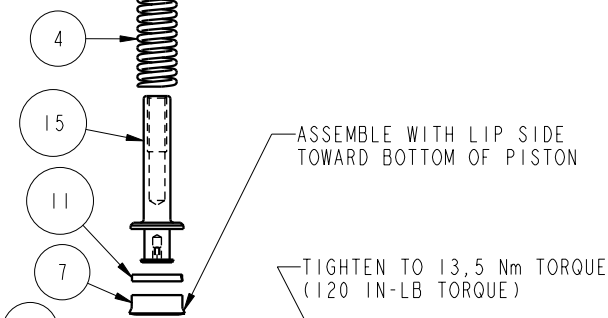
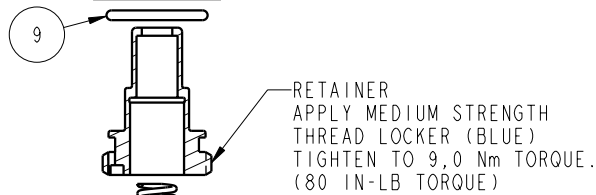
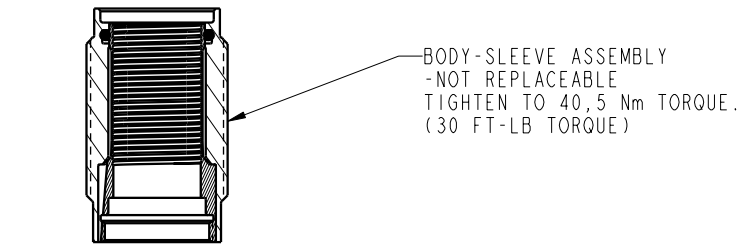
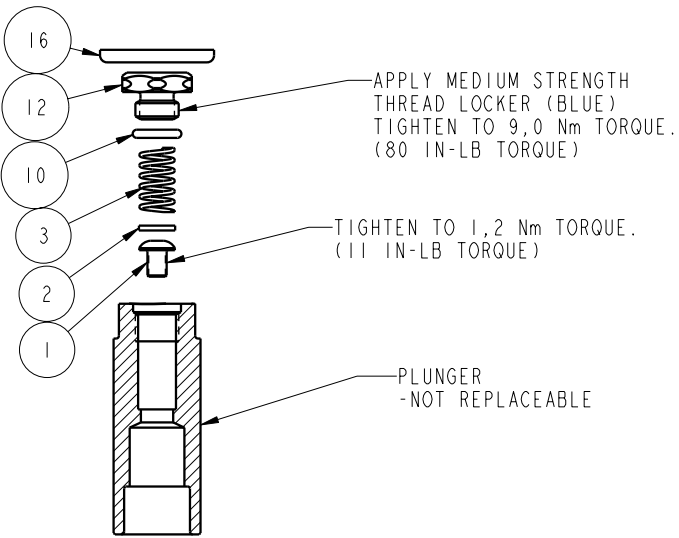

VEKTEK, INC.  
1334 E. SIXTH AVE. P.O. BOX 625  
EMPORIA, KS. 66801 U.S.A.

ASSEMBLIES AFFECTED

41007004

41007004F

PARTS LIST, ASSY, WS, FA, BM, 4.4 KN

SIZE  
A

MPL1064

REV  
F

F	2607	RELEASE	GAR	2/11/14
REV	IN ACCORDANCE WITH ECN	EFFECTIVE DATE	REVISED BY	DATE
DRW BY:	JDW	<b>DRAWING STATUS: Released</b>		
DATE:	8-22-07	PRODUCTION APPROVED FOR RELEASED STATUS ONLY		

FORM FEG035\_PL\_ASIZE, REV. B

SHEET 1 OF 1

Vekttek, Inc. 1334 East Sixth Ave. P.O. Box 625 Emporia, Ks. 66801 U.S.A.	Instruction Sheet	ISMV	1003		
		REV:	G, I.A.W. ECN2386		
		REV. BY/DATE:	JDW	5-4-12	
		APPR/DATE:	JAM	6-22-12	
<b>TITLE: Disassembly/Assembly Instructions: 4.4 &amp; 11 kN Fluid Advance Work Supports</b>					

Read all instructions before disassembly

Refer to the illustration on page three for component part numbers and a tool list.

## Disassembly

**Notice: When disassembling multiple work supports, the plunger and body/sleeve assembly from each work support should be kept together.**

1. Unscrew the body/sleeve assembly (9) from the base (15) or fixture. **Caution- Use a six-point socket only. Other types of wrenches may damage the work support.**
2. Hold the plunger (6) stationary and unscrew the contact bolt (1). Remove o-ring (16) from contact bolt (1).
3. Remove the spring (2) and spacer (10) from inside the plunger (6).
4. Hold the piston (8) stationary and unscrew the cap screw (3).
5. Slide the plunger (6) out of the top of the body/sleeve assembly (9) and then push the piston (8) and spring (13) out of the retainer (14).
6. Remove the wiper (7) from the body/sleeve assembly (9). **Do not scratch the inner sleeve.**
7. Hold the body/sleeve assembly (9) stationary and unscrew the retainer (14) from the body/sleeve assembly (9) using a spanner wrench.
8. Remove the piston seal (11) and piston seal back-up ring (12) from the piston (8), the O-ring (5) from the retainer (14) and the gasket (4) from the base (15) or fixture.
9. Clean all parts thoroughly and set aside to dry.

Vekttek, Inc. 1334 East Sixth Ave. P.O. Box 625 Emporia, Ks. 66801 U.S.A.	Instruction Sheet	ISMV	1003	
		REV:	G, I.A.W. ECN2386	
		REV. BY/DATE:	JDW	5-4-12
		APPR/DATE:	JAM	6-22-12
<b>TITLE: Disassembly/Assembly Instructions: 4.4 &amp; 11 kN Fluid Advance Work Supports</b>				

## Assembly

1. Lubricate all O-rings, gaskets, back-up rings and seals with clean hydraulic fluid (Vekttek 65-0010-01 or equivalent). Apply Loctite primer N® or equivalent to the threads of the contact bolt (1) and the retainer (14) and set aside to dry.
2. Press the wiper (7) into the body/sleeve assembly (9) using only enough force to seat the wiper in the counterbore. **Caution:** Excess force may cause the inner sleeve to collapse.
3. First install the back-up ring (12) then the piston seal (11) onto the piston (8) with the sealing lips of the piston seal (11) toward the piston (8) base.
4. Install the O-ring (5) onto the retainer (14).
5. Apply Loctite 243® or equivalent to the threads of the retainer (14).
6. Hold the body/sleeve assembly (9) stationary and screw the retainer (14) into the body/sleeve assembly (9). Tighten to the torque specification on the parts list.
7. Slide the spring (13) onto the piston (8) and insert both parts into the retainer (14)
8. Insert the plunger (6) into the top of the body/sleeve assembly (9).
9. While holding the piston (8) stationary insert the cap screw (3) into the top of the plunger (6) and thread the cap screw (3) into the piston (8). Tighten to the specification on the parts list.
10. Insert the flat washer (10) and the spring (2) into the top of the plunger (6).
11. Install o-ring (16) onto contact bolt (1). Apply one drop of Loctite 243® or equivalent to the threads of the contact bolt (1). While holding the plunger (6) stationary tighten the contact bolt (1) to the plunger (6). Tighten to the torque specification on the parts list.
12. Place the gasket (4) flat in the bottom of the base (15) or mounting cavity. Insert the work support assembly into the base (15) or mounting cavity and tighten it to the torque specification on the parts list.  
**Caution- Use a six-point socket only. Other types of wrenches may damage the work support.**

<b>Vekttek, Inc.</b> 1334 East Sixth Ave. P.O. Box 625 Emporia, Ks. 66801 U.S.A.	<b>Instruction Sheet</b>	<b>ISMV</b> <b>1003</b>
		<b>REV:</b> <b>G, I.A.W. ECN2386</b>
		<b>REV. BY/DATE:</b> <b>JDW</b> <b>5-4-12</b>
		<b>APPR/DATE:</b> <b>JAM</b> <b>6-22-12</b>
<b>TITLE: Disassembly/Assembly Instructions: 4.4 &amp; 11 kN Fluid Advance Work Supports</b>		

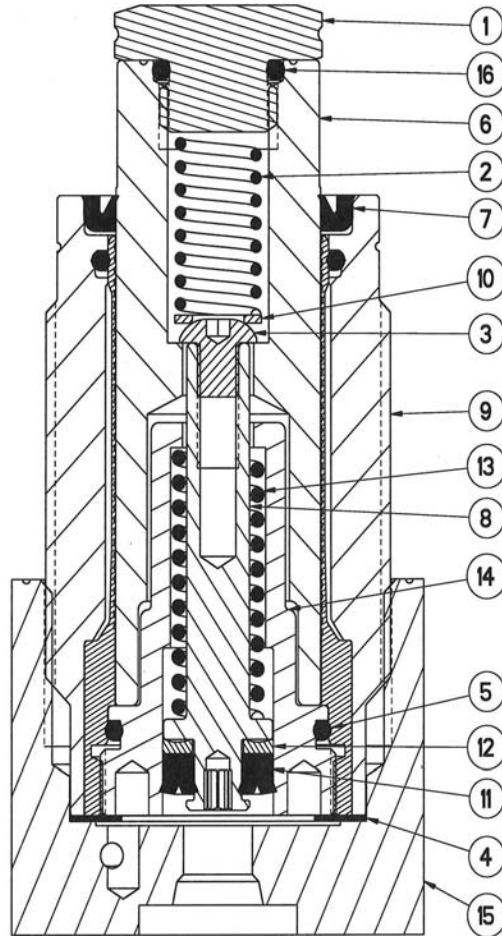

16	O-RING
15	BASE
14	RETAINER
13	SPRING
12	BACK-UP RING
11	SEAL
10	SPACER
9	BODY/SLEEVE ASSY
8	PISTON
7	WIPER
6	PLUNGER
5	O-RING
4	GASKET
3	CAP SCREW
2	SPRING
1	CONTACT BOLT
Item	Description

Model Number	Tool List
41-0070-00 41-0070-04 41-0070-14 41-0071-00 41-0071-04 41-0071-14 6964H-04-1 6964H-04-2	14 mm open end, 13 & 23 mm socket (six point) 1/16 & 5/64 hex keys, spanner wrench
41-0070-01 41-0070-03 41-0070-13 41-0071-01 41-0071-03 41-0071-13 6964H-11-1 6964H-11-2	18 mm open end, 19 & 30 mm socket (six point) 1/8 & 3/32 (2) hex keys, spanner wrench